

# Detecting Earthquakes

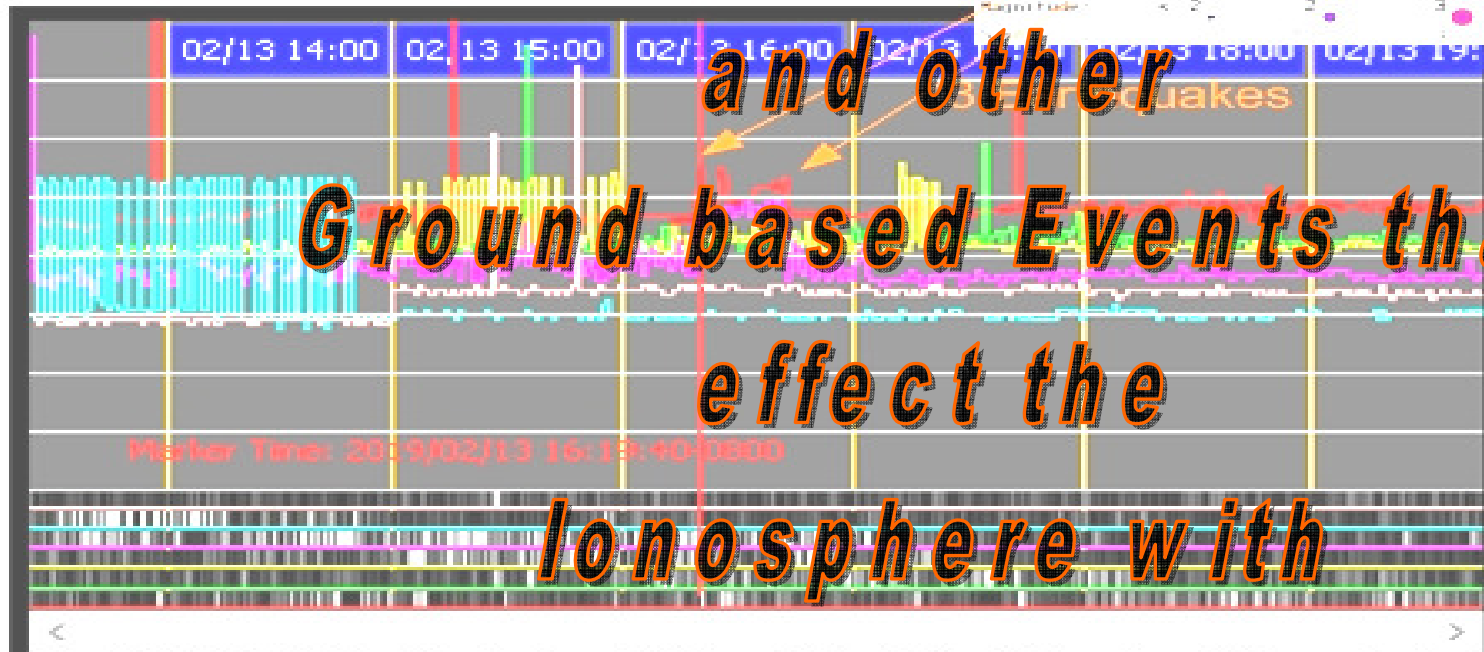

2019-02-13: M=4.0 - 183 km W of Port Hardy, BC - offshore  
2019-02-13: M=5.1 - 188 km W of Port Hardy, BC - offshore  
2019-02-13: M=4.1 - 188 km W of Port Hardy, BC - offshore

by  
**Alex Schwarz**  
**(VE7DXW)**

# How do Earthquakes create Electromagnetic Fields?

- Piezoelectric effect of rocks sliding and vibrating on top of each other.
- Micro-Fractures of rocks releasing vast amounts of free electrons.
- Electrons move up towards the surface or sea-floor and circulate around the quake area.
- Electromagnetic fields start to emerge out of the earth crust and move upward towards the ionosphere.
- Since the ionosphere contains charged particles, the magnetic field interacts with the ions and creates a hole or a dome of charged particles, affecting radio waves passing through.
- For more information see Scientific American Oct. 2018: “Earthquakes in the Sky” (see ref. at the end)

# A hole in the Ionosphere?

- The magnetic field lines reach into the ionosphere and disturb or bend the layers, breaking existing radio paths. The signals that the Seismograph receives drop out!

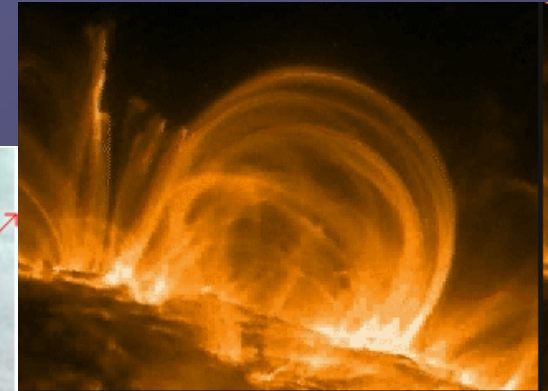
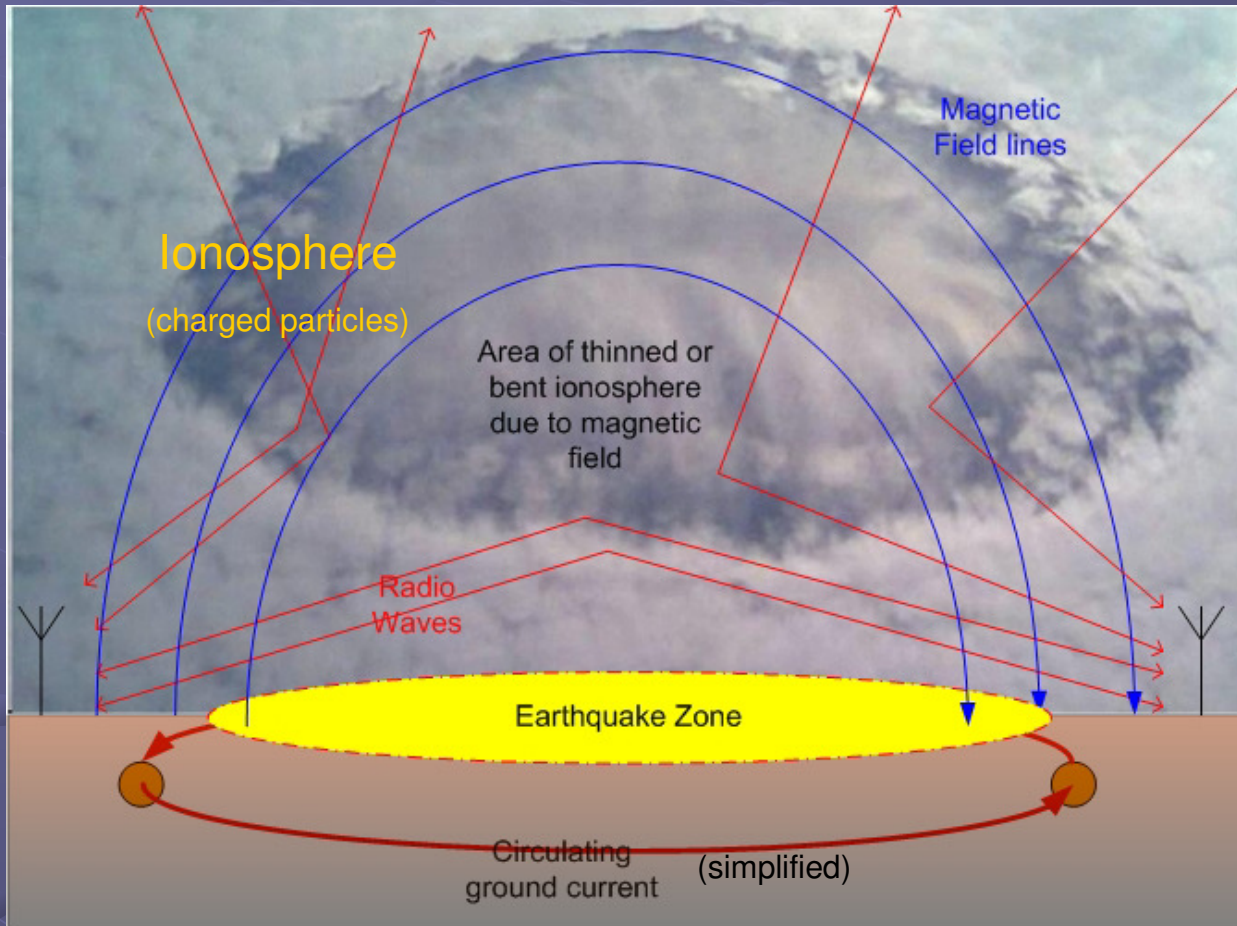

The equivalent of a magnetic field shooting out of the surface of the sun. Because of the hot plasma, the field lines are visible. This process on the sun is much more energetic than an earthquake here on earth, but the physics are the same.

# What is visible on the RF-Seismograph

- **The different stages of the quake as seen by the RF-Seismograph**  
(case study for M5.0 event, 256 km SW of Pt. Hardy - N-Vancouver Island, BC)
  - Energy buildup – noise increases on 80m (red).
  - Disruption of 40, 30 and 20m band – communication dropout.
  - Quake releases.
  - The energy buildup and blackout continues with most quakes for approx the same time as the before the quake (2 to 8h) for at total of 4 to 16h.
  - After the energy releases, the ionosphere starts to rebuild slowly and normal communication continues.

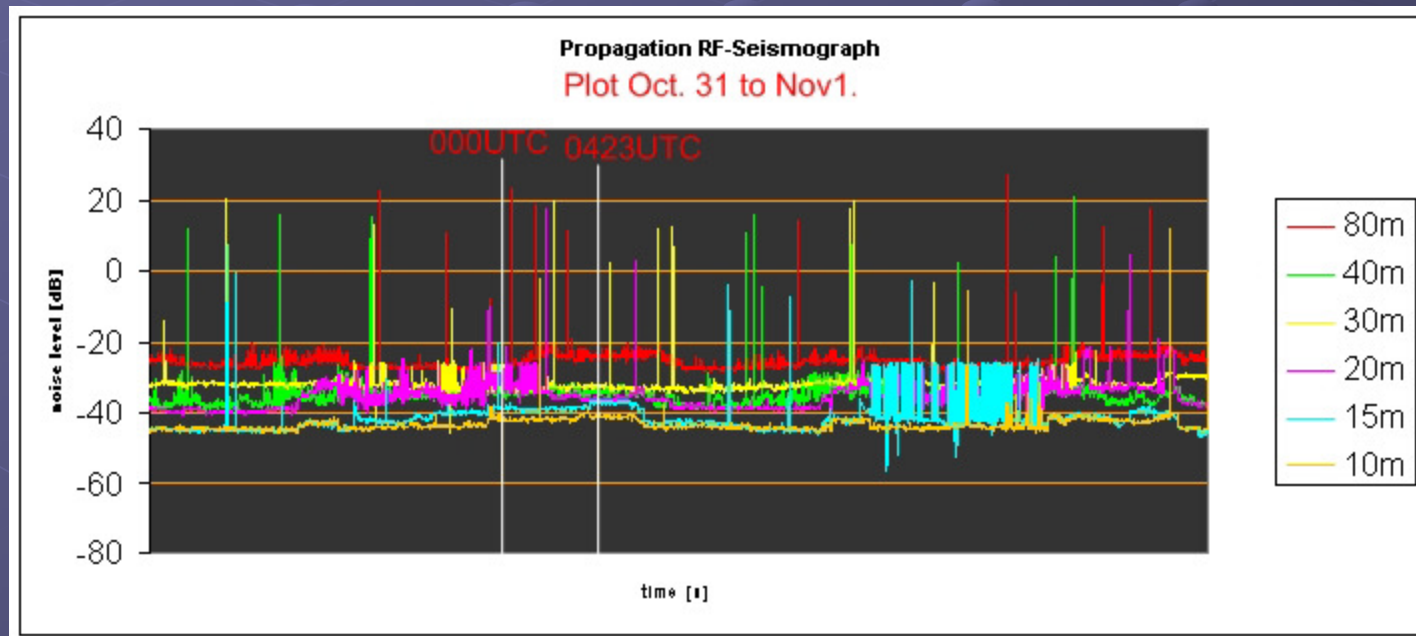

# How to store and search the data we have collected

Timestamp	3576000	7076000	10138000	14076000	21076000	28076000
2/12/2019 23:41	-36.65	-39.51	-41.9	-50.22	-53.72	-55.76
2/12/2019 23:42	-38.24	-40.31	-41.48	-50.43	-54.17	-55.13
2/12/2019 23:42	-38.1	-40.62	-42.06	-51.12	-54.5	-55.94
2/12/2019 23:43	-37.99	-39.44	-41.81	-49.87	-54.21	-55.78
2/12/2019 23:44	-36.86	-39.75	-41.77	-49.24	-55.24	-55.89
2/12/2019 23:45	-37.1	-39.62	-41.41	-50.26	-54.88	-55.41
2/12/2019 23:46	-37.42	-39.79	-41.27	-51.25	-54.78	-55.81
2/12/2019 23:47	-36.53	-38.22				
2/12/2019 23:48	-35.92	-38.37				
2/12/2019 23:49	-37.25	-40.41				
2/12/2019 23:50	-37.72	-39.75				
2/12/2019 23:51	-36.73	-39.38				
2/12/2019 23:51	-36.05	-39.7				
2/12/2019 23:52	-36.65	-39.65				
2/12/2019 23:53	-36.87	-39.88				
2/12/2019 23:54	-36.38	-40.15				

Collecting information on propagation creates huge files. The RF-Seismograph measures 6 bands every 52s. It creates a log file every day at midnight and has collected over 105MB of data since it was started recording.

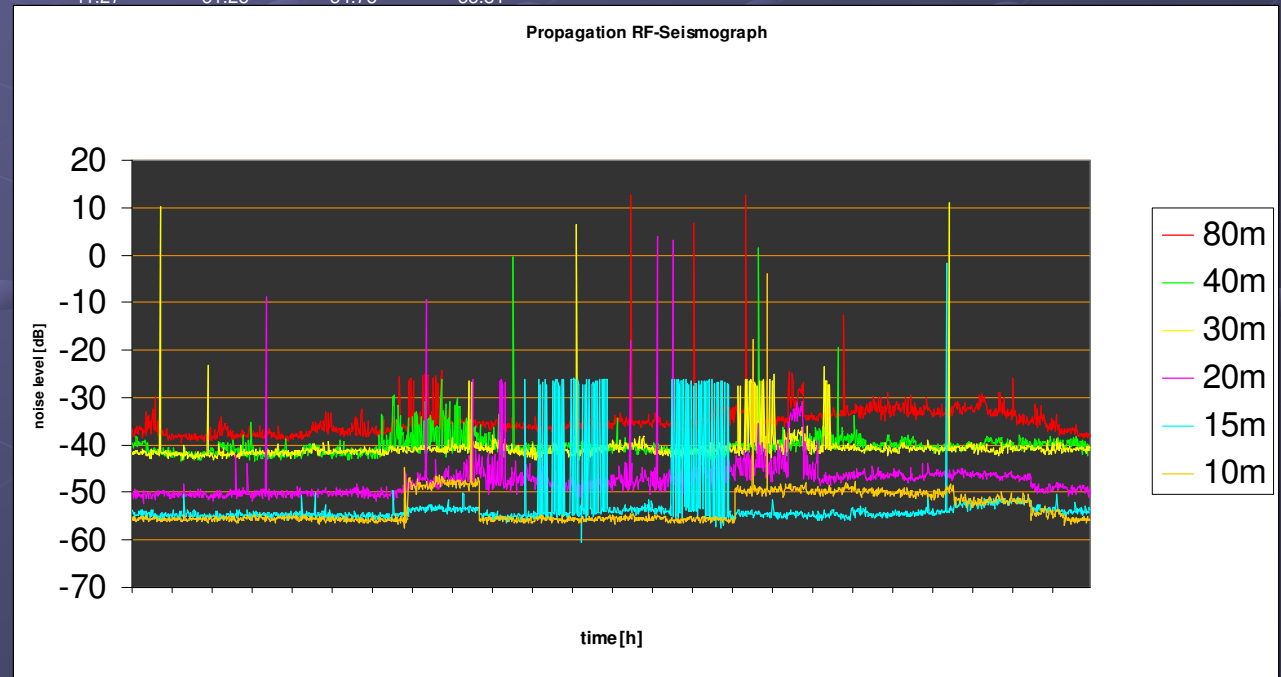

# How sensitive is the RF-Seismograph!

In the first phase of our research we were looking at small events. Preferably something man-made. North Korea came to mind, which has been conducting underground atomic tests. The bomb that exploded on Sep. 09. 2016 at Punggye-ri site was estimated to be 15 to 25kt (just a bit larger than Hiroshima). If exploded on the surface it has the power to create a M6+ size earthquake!

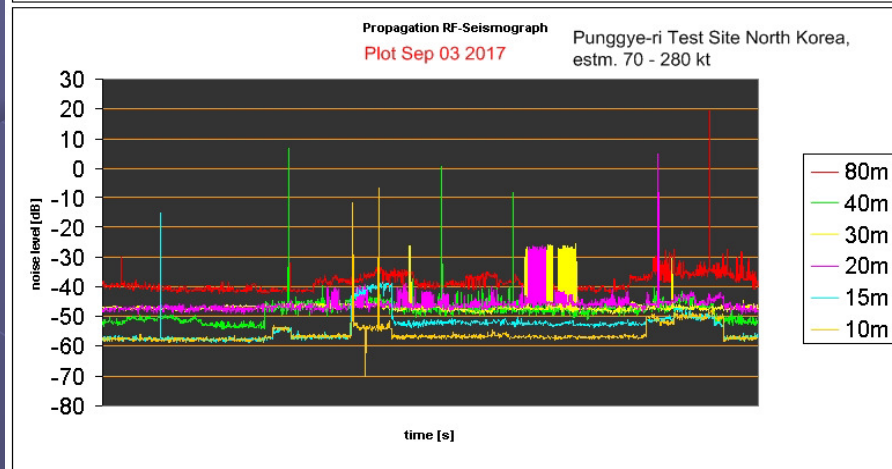
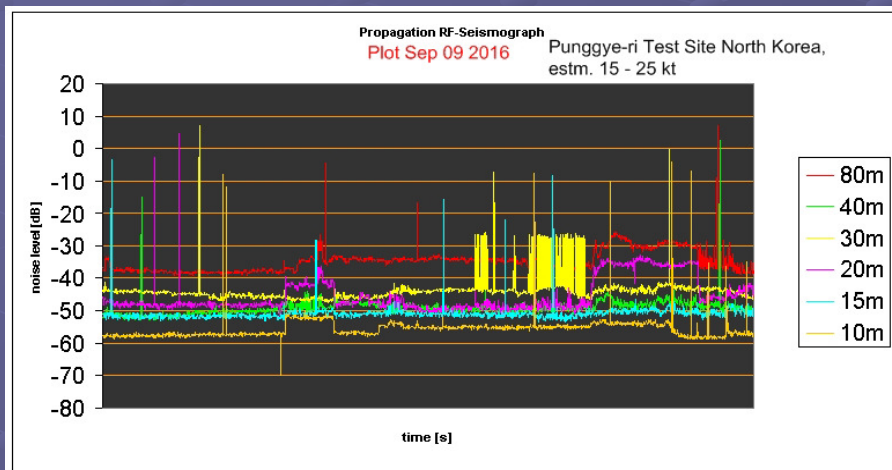

Since the test was underground the effect on the surface, the ionosphere and the EMP, were much attenuated. Never the less the RF-Seismograph recorded a blip, a delayed reaction and a change in propagation.

The second event was much larger and had a yield of 70 to 280kt but the time of the explosion does not match our data (listed on Wikipedia).

So the jury is still out...,but why the times are different is anyone's guess!

# The long term effect of Solar Flux

On August 2016 the Solar Flux was at 100. The average noise level at the MDSR Space Weather Station was -40dB on 80m and -58dB on 10m.

On Nov 25 2018 the Solar Flux was at 70 (the start of solar min). And the average noise level of the station has actually increased!

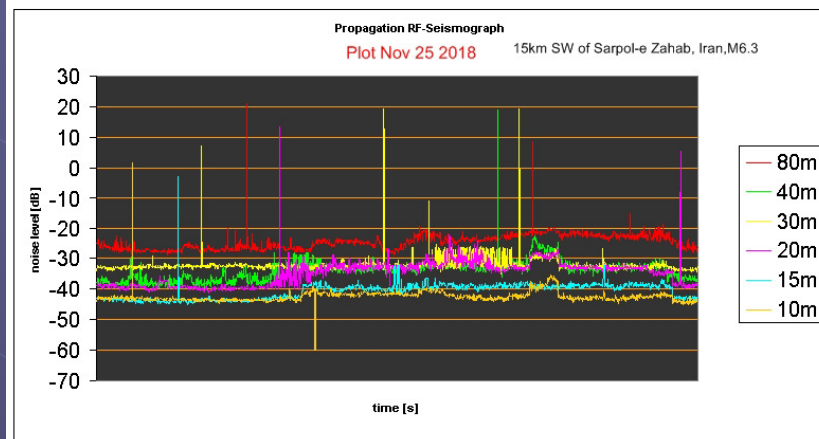
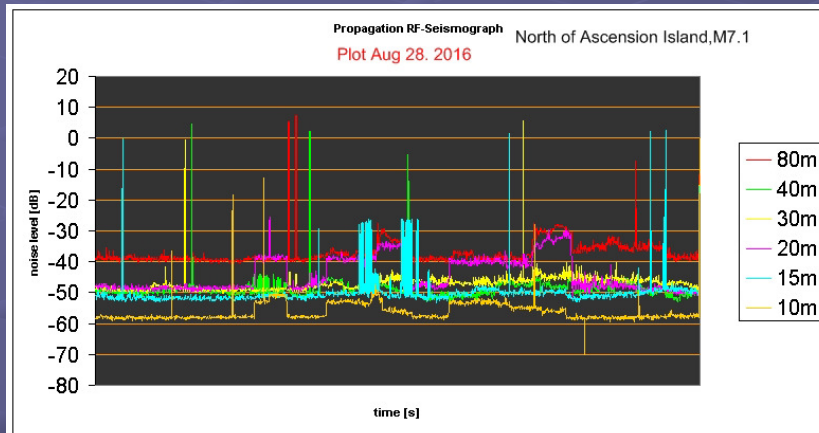

SFi at 100 will not help to open 15 (blue) and 10m (salmon) so there is little activity on these bands. Unfortunately the RF-Seismograph was not available during last solar max.

**Conclusion:** High solar flux makes the ionosphere more conductive so it radiates the local noise to other locations and hence the noise level drops.

**Note:** Both measurements were taken on days that were quiet in terms of solar activity and solar wind.

# The different types of measurement (Passive and semi passive measurement)

The RF-Seismograph performs a passive and semi-passive measurement at the same time.

- The passive measurement only records the noise level.
- The semi-passive measurement is taken mainly on the digital section of each band (such as JT-65 and FT-8).

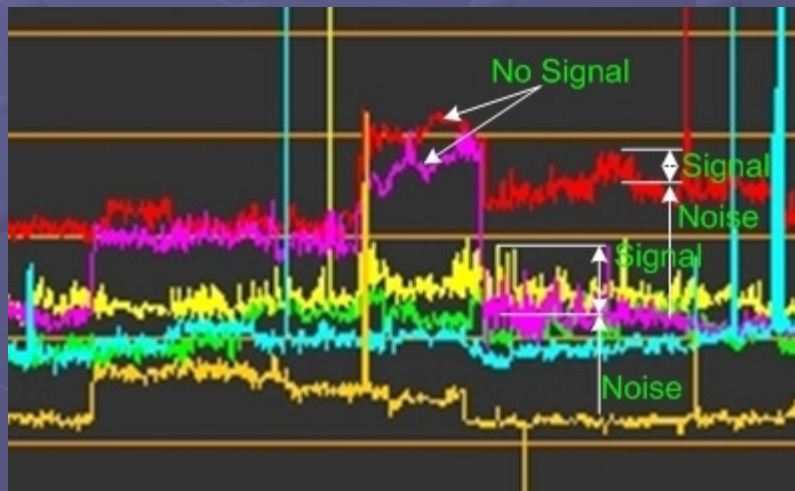

- no changes to the noise level: the result is a flat line.
- no signal present: the MDSR displays a thin line which moves up and down recording the noise level.
- with a signal present: the graph goes wide and moves up and down with the noise level.

# The 4 Year Propagation vs. Earthquake Study

- 171 total Earthquakes were studied: All M6+ events from the beginning of our recording (Aug 2016) to today. Events were provided by USGS and the quality of the data is high.
- 961 days of recorded data, 171 Quakes M6+, that amounts to one major quake every 5.6 days. Approximately 17.3% of background noise is affected by these strong events. Since we did only look at 6+ events, we can conclude that a lot of the background noise we monitor is created by smaller seismic events as well (and there is a lot more of them). If one looks at smaller quakes the (<M3.0) the earth really never stops shaking. There is a lot of energy even in small quakes and they are the major source of the rumble one hears when a HF rig is set to 160m or 80m.
- Only 15 quakes did not have RF noise associated with them.
- 1 day out of 961 was not recoverable due to data loss. In 26 cases the time of the disturbance did not match the time stated in the USGS report.
- In 122 Quakes (72%) we were able to see a noise increase of the 80m either before, after and before and after the quake released. The before and after is the most common one. More analysis is needed.
- Introduction and Study of Earthquakes (see ref. at the end)  
<http://www3.telus.net/public/bc237/MDSR/IntroductionRF-SeismographandEarthqakes.pdf>
- The study is still continuing and we need your help to set up more monitoring stations.

# *Why do we need big antennas to monitor Propagation and Noise*



When monitoring background noise, it is imperative to use a big, preferably omnidirectional antenna like the 18HTjr from Hy-Gain. This antenna is capable to cover all the major amateur bands including 80m. Each band that we record must have a defined resonant element on this antenna. Big antennas are not only more efficient; they are also a lot less interference prone due to local near field changes. This means that some maintenance can be done without having to turn off the RF-Seismograph. Especially when the monitoring is over long periods of time, maintaining the antenna while it is recording with a minimum of interference is a big plus.

# How is “RF Seismograph” connected to the Transceiver

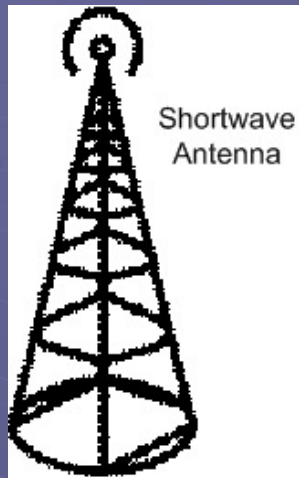

The station setup for the RF-Seismograph is exactly the same as for the MDSR. The 455kHz IF is extracted from the transceiver and then fed to the LIF converter. The LIF converts the IF to 12 – 15kHz. The Output of the LIF is connected to LINE IN of the Soundcard. (24ADC for best performance)

**The MDSR software needs to be installed.**

RF-Seismograph is part of the MDSR software package.

Download at: <http://users.skynet.be/myspace/mdsr/>

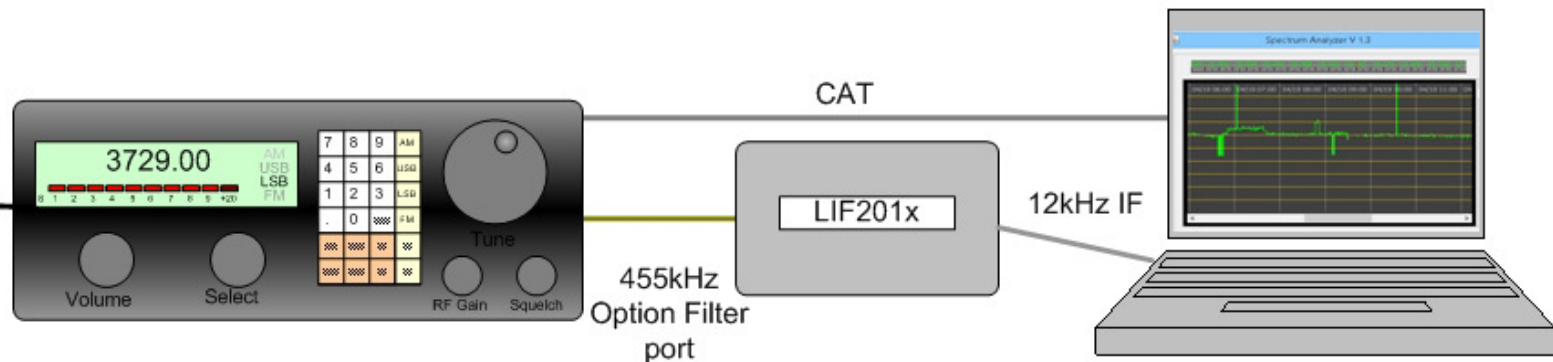

# Hardware Implementation

The hardware design of the Raspberry Pi setup to run the RF-Seismograph has to include a sound-card with stereo line level output and input. The higher the quality of the sound-card input the better the results for the received and demodulated signal. The Raspberry Pi unit requires 5V and draws up to 2A from the power source. This is different from all the amateur equipment that usually requires 13.8V.

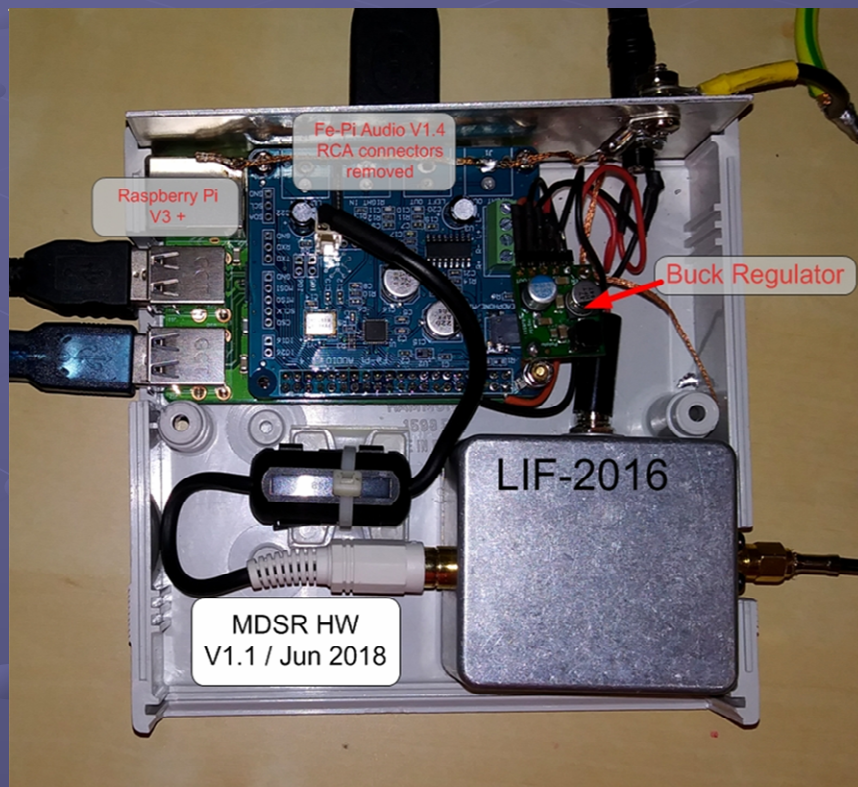

To simplify the setup of the unit a Buck voltage regulator is implemented to reduce the 13.8V to 5V for the Pi. Since this is done internally the PI power connector remains empty. The connection between the LIF-2016 and the left audio line input is wired with high quality shielded audio cable. To reduce inductive RF currents on the shield, a clamp-on ferrite bead is placed over the cable. Grounding is required to reduce the induction of noise generated by the microprocessors and other digital circuits. For best grounding results, follow the schematics for grounding points.

Software setup is described in the [MDSR.io](https://www.mdsr.io/) group Wiki.

# RF-Seismograph setup for Portable use

The Linux version of the RF-Seismograph can also be set up for touch screen and portable operation. The Raspberry Pi and the sound card are mounted on the back of the screen. The radio is controlled via CAT interface. The LIF-2016 is required to connect the IF to the sound card.



5V 2A power is supplied via a 12V car power adaptor. The LIF interface (cast metal box) requires 12V/10mA power.

As always, receiver has to be modified for IF output, which the LIF converts to audio level.

To check out what transceivers can be adapted to use with the LIF interface check out our website at;

<http://users.skynet.be/myspace/mdsr/index.html>

or our Groups.io/MDSR group at:

<https://groups.io/g/MDSRadio>

# LIF 2016

- Fits into the option filter slot of many Yaesu and other radios
  - PCB size: 56 x 22mm (2.2 x 0.850") same pin out as option filter
- Only requires +12V to be wired from inside the radio
- 12 - 15kHz output ready for the Sound Card on TB3
  - RX only

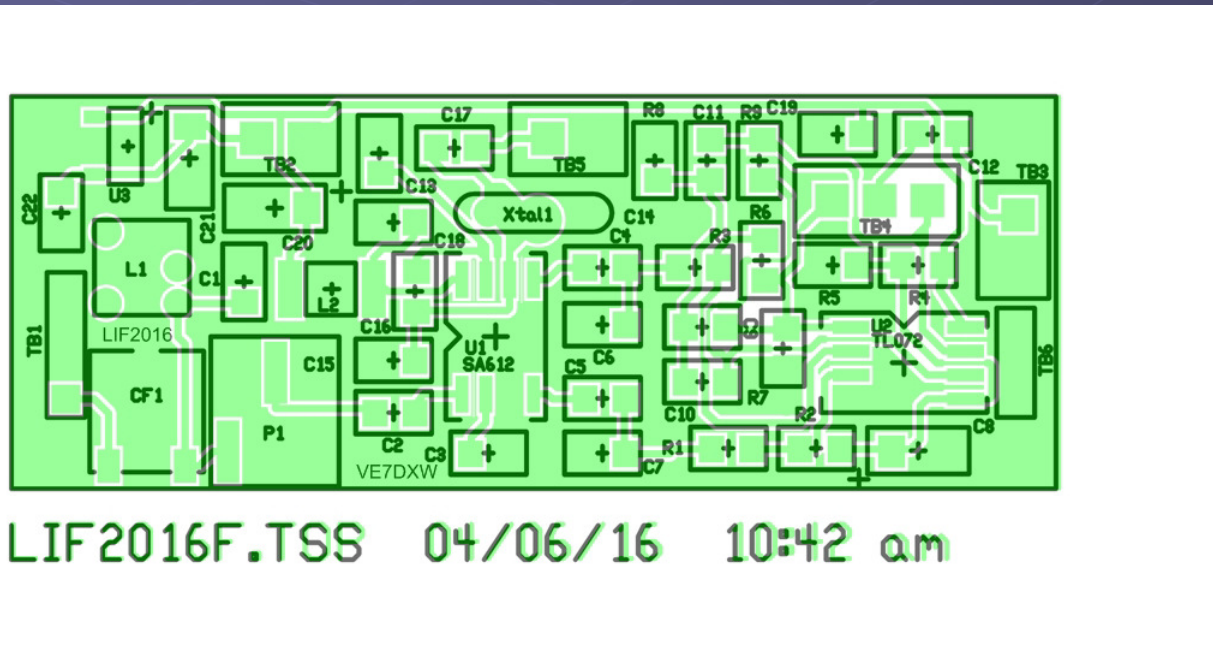

# Conclusions

- Earth magnetic field seems to be way more complicated than what we learn in school. It is much more, on a smaller scale, as the sun, where field lines emerge from almost anywhere. The poles have the strongest field lines, but are not the only place where they can appear.
- Earthquakes are huge generators of RF-white noise. They use their field lines as antennas and the shockwaves reverberate around the planet.
- These shockwaves emerge in most cases about 1 to 3h before the quake releases and are detectable via a RF-receiver.
- The advantage of using HF is, that the propagation of the waves received is worldwide. This allows one radio to be able to hear most of the quakes as the RF-Seismograph has demonstrated.
- The field lines generated by a quake have the possibility to disrupt radio communications; sometimes for hours.
- New science sheds a light on all the different aspects of a quake. There is much more going on than just mechanical movement!

# References

Scientific American Oct. 2018: “Earthquakes in the Sky”

[http://www.ep.sci.hokudai.ac.jp/~heki/pdf/Scientific\\_American\\_Vance2018.pdf](http://www.ep.sci.hokudai.ac.jp/~heki/pdf/Scientific_American_Vance2018.pdf)

Earthquakes Canada:

<http://www.earthquakescanada.ca>

U.S. Geological Survey

<https://www.usgs.gov/>

Access to Study for 2017, 2018 (2019 is part of 2018)

[http://www3.telus.net/public/bc237/MDSR/Matches-RF-Seismograph and Seismic data for 2017.pdf](http://www3.telus.net/public/bc237/MDSR/Matches-RF-Seismograph_and_Seismic_data_for_2017.pdf)

[http://www3.telus.net/public/bc237/MDSR/Earthquakes visible with RF-Seismograph 2018.pdf](http://www3.telus.net/public/bc237/MDSR/Earthquakes_visible_with_RF-Seismograph_2018.pdf)

Download and Install RF-Seismograph for Linux and Raspberry Pi

<https://groups.io/g/MDSRadio/wiki/home>

Download MDSR software for PC from:

<http://users.skynet.be/myspace/mdsr/>

# Questions?

## Contact information:

Alex Schwarz: [alexschwarz@telus.net](mailto:alexschwarz@telus.net)

Website: <http://users.skynet.be/myspace/mdsr/>

IO Groups user group: <https://groups.io/g/MDSRadio>

SciStarter: <https://scistarter.com/project/21138-RF-Seismograph>

Thank you for your interest and participation in this  
presentation

Kits are available from VE7DXW

© 2019